

4 IN 1 WORK SUPPORT

Workbench, Work Platform
Modell: **BT180000**

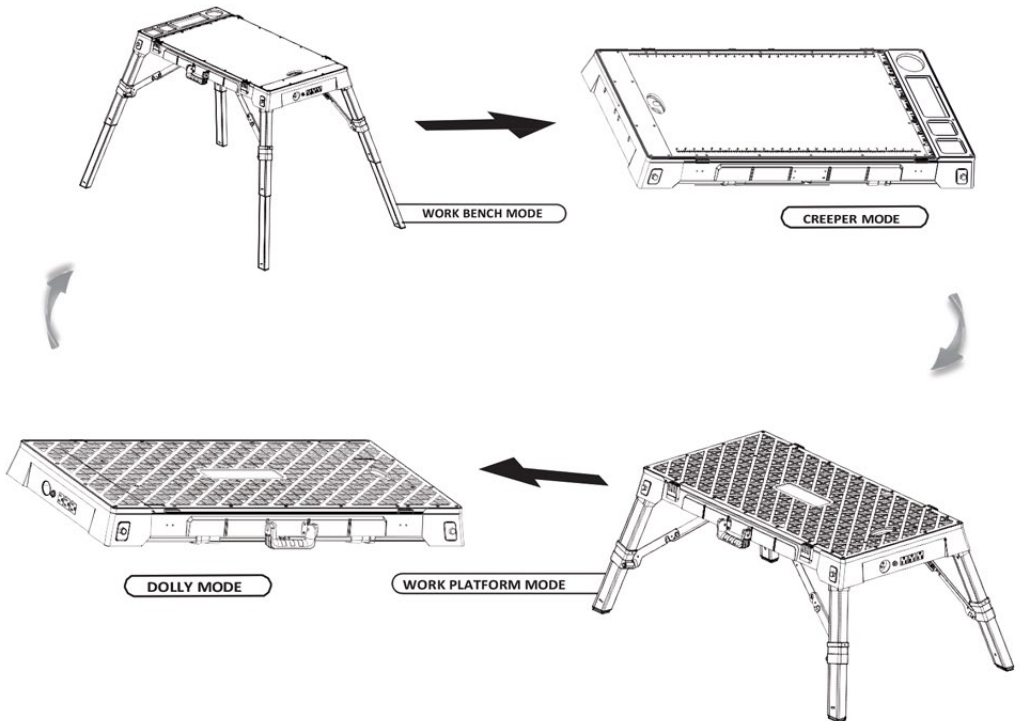

IMPORTANT SAFETY INSTRUCTIONS

TO REDUCE THE RISK OF INJURY, READ AND UNDERSTAND ALL INSTRUCTIONS BEFORE USING THIS PRODUCT. FAILURE TO FOLLOW ALL INSTRUCTIONS BELOW MAY RESULT IN SERIOUS PERSONAL INJURY.

SAVE THIS MANUAL FOR FUTURE REFERENCE.

GENERAL SAFETY INSTRUCTIONS

Do not store this product outdoors or in a humid environment, as this may cause damage to the product.

When using this product in the work platform mode, keep your feet firmly planted in the center of the platform. Do not step on the four corners of the product surface, as this may cause the product to tip over and result in personal injury.

When using this product in the work platform or workbench modes, place objects in the center of the product's surface. Placing objects on the corners may cause the product to tip over.

When extending or retracting the legs, do not use excessive force, as this may damage the product.

Before using this product, make sure that the legs are firmly locked in position and the latches are closed tightly over the top panel.

Do not use or alter this product for any purpose other than specified in this manual.

When using this product with power tools, refer to the manufacturer's instructions for how to properly use electric tools. Always wear safety goggles.

MAX. POWER RATING:

125 Volts, 15 Amps, 1875 Watts

WEIGHT CAPACITIES:

Do not exceed the following weight capacities:

MODE	WEIGHT CAPACITY
Workbench	330 lbs
Work platform	330 lbs
Dolly	265 lbs
Creepers	265 lbs

CHANGING MODES

CREEPER /DOLLY MODE TO WORKBENCH MODE

1. Put the Creeper /Dolly on its back and pull back on the spring loaded locking pins from one leg and pull the leg upward.

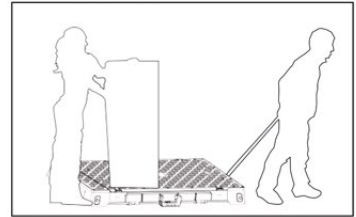

Two holes are provided on one end of the product for attaching a traction rope connector when moving heavier objects.

Exercise caution when moving heavy objects.

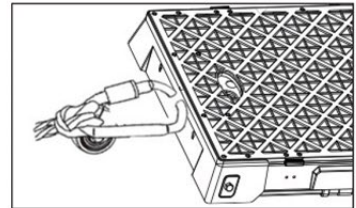

CREEPER MODE

Use this mode to perform jobs in low spaces. Also put the product into this mode when storing or moving it. A carrying handle is provided.

CAUTION: Do not step or stand on the work surface in creeper mode.

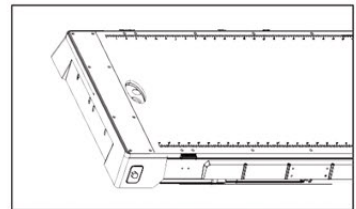

DOLLY MODE

Place objects in the center of the platform surface. Exercise caution when moving tall objects to prevent them from sliding or falling over.

CAUTION: Do not step or stand on the work platform surface in dolly mode.

NOTE: You must pull out the spring loaded locking pins when opening the legs. Otherwise they will be damaged and may not open.

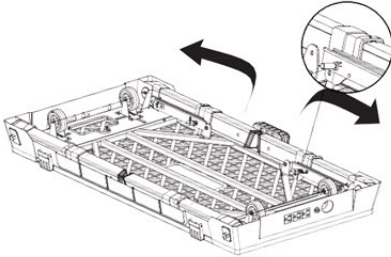

2. Pull each leg up and out and extend hinged bracket until it locks in place.

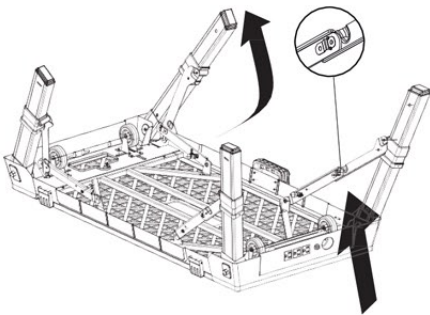

3. Press the spring button on each leg and pull each leg out until the spring button clicks again.

CAUTION: Make sure the spring button on each leg clicks out before using the product. Failure to do so may result in the legs retracting during use.



WORKBENCHMODE TO WORKPLATFORM MODE

1. Press in the spring button on each leg and slide the leg in.



2. Open the four latches on the sides (two latches per side).

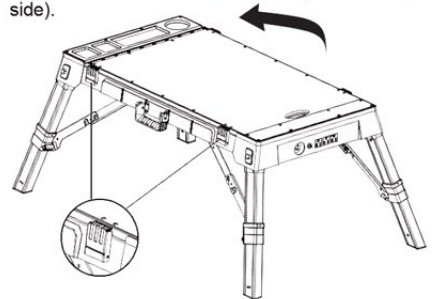

3. Remove the panel, turn it over so that the anti-slip work platform surface is face up, and place it back onto the platform. Re-fasten all four latches.

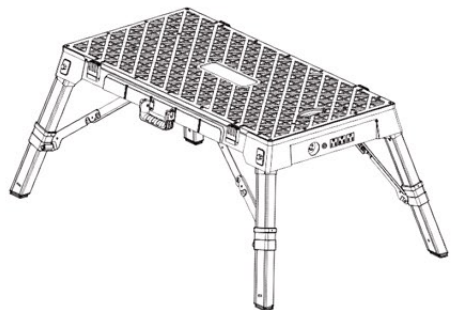

WORK PLATFORM MODE