

PORTAVALIGIA SPECIFICO - SPECIFIC CASE HOLDER
 PORTE-VALISE SPÉCIFIQUE - SPEZIFISCHER KOFFER-TRÄGER
 PORTA-EQUIPAJE ESPECÍFICO

PIAGGIO MP3 '06/'08

125 - 250cc

ISTRUZIONI DI MONTAGGIO - MOUNTING INSTRUCTIONS
 INSTRUCTIONS DE MONTAGE - BAUANLEITUNG - INSTRUCCIONES DE MONTAJE

①



SUPPORTO
 SUPPORT
 SUPPORT
 HALTERUNG
 SOPORTE

Q.TY n.2(Dx-Sx)

②



VITE TBEI M8x35mm
 SCREW M8x35mm
 VIS M8x35mm
 SCHRAUBE M8x35mm
 TORNILLO M8x35mm

Q.TY n.2

③



VITE TBEI M8x30mm
 SCREW M8x30mm
 VIS M8x30mm
 SCHRAUBE M8x30mm
 TORNILLO M8x30mm

Q.TY n.2

④



VITE TCEI M6x35mm
 SCREW
 VIS
 SCHRAUBE
 TORNILLO

Q.TY n.4

⑤



RONDELLA Ø6mm
 WASHER Ø6mm
 RONDELLE Ø6mm
 SCHEIBE Ø6mm
 ARANDELA Ø6mm

Q.TY n.4

⑥



RONDELLA Ø6x20mm
 WASHER
 RONDELLE
 SCHEIBE
 ARANDELA

Q.TY n.4

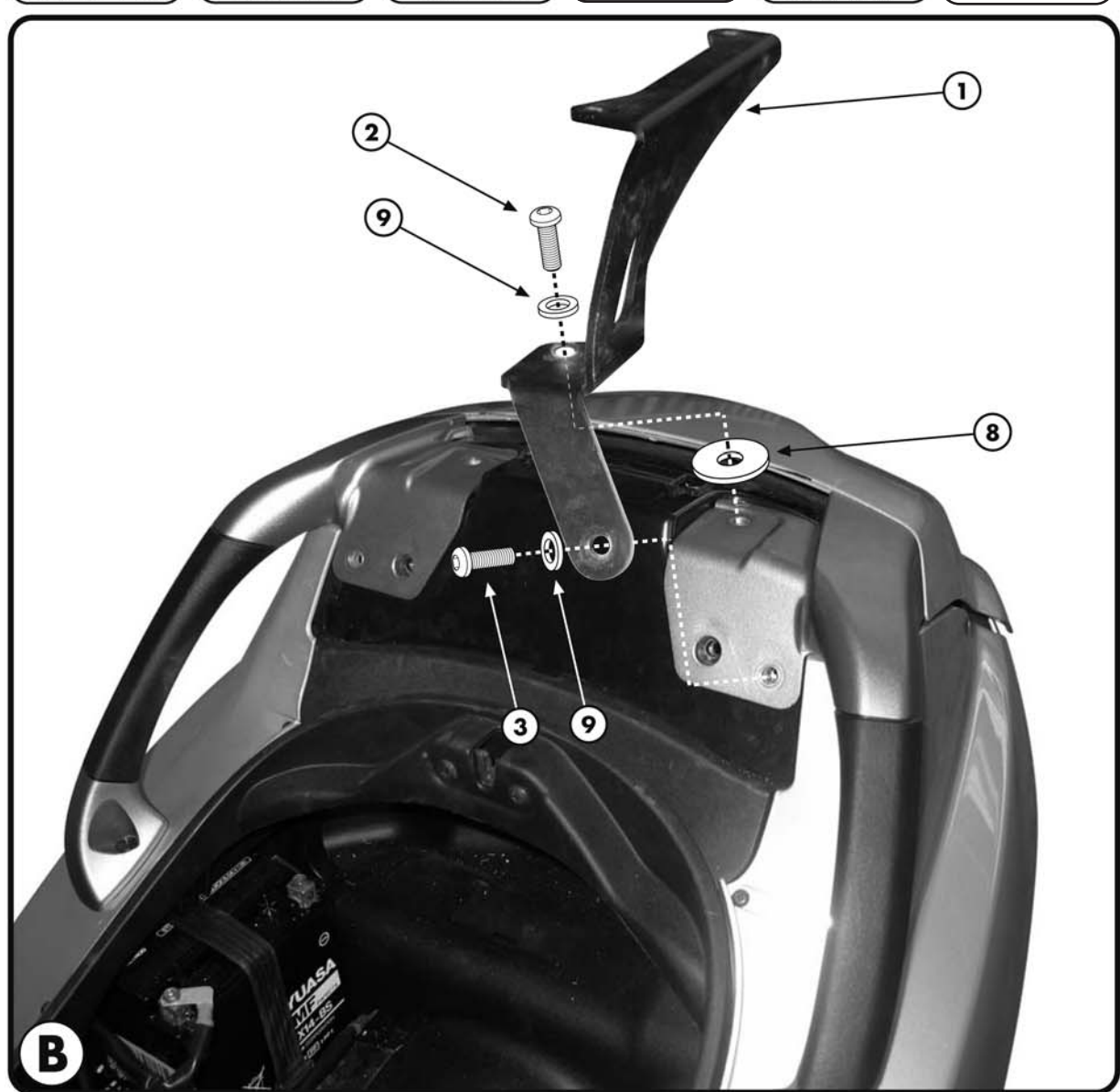

ATTENZIONE
 PESO MASSIMO SOPPORTABILE 6Kg.

WARNING
 MAX. LOADING OF THE CARRIER 6Kg. (13lbs)

ATTENTION
 CHARGE MAXIMALE 6Kg.

ACHTUNG
 MAXIMALE BELASTUNG 6Kg.

¡ATENCIÓN!
 CARGA MÁXIMA AUTORIZADA 6Kg.

PORTAVALIGIA SPECIFICO - SPECIFIC CASE HOLDER
 PORTE-VALISE SPECIFIQUE - SPEZIFISCHER KOFFER-TRÄGER
 PORTA-EQUIPAJE ESPECÍFICO

PIAGGIO MP3 '06/'08

125 - 250cc

ISTRUZIONI DI MONTAGGIO - MOUNTING INSTRUCTIONS
 INSTRUCTIONS DE MONTAGE - BAUANLEITUNG - INSTRUCCIONES DE MONTAJE

7



RONDELLA 16x2mm
foro Ø6,5mm
 WASHER Ø6mm
 RONDELLE Ø6mm
 SCHEIBE Ø6mm
 ARANDELA Ø6mm

Q.TY n.2

8



RONDELLA Ø8x20mm
 WASHER Ø8x20mm
 RONDELLE Ø8x20mm
 SCHEIBE Ø8x20mm
 ARANDELA Ø8x20mm

Q.TY n.2

9



RONDELLA Ø8x14mm
 WASHER Ø8x14mm
 RONDELLE Ø8x14mm
 SCHEIBE Ø8x14mm
 ARANDELA Ø8x14mm

Q.TY n.4

10



DADO A.B. M6
 BOLT M6
 ECROU M6
 MUTTER M6
 TUERCA M6

Q.TY n.4

11



PIASTRA MONOLOCK
 Z667M
 PLATE
 PLATINE
 PLATTE
 PARRILLA

Q.TY n.1

12



COPRIFORO
 Z621
 BOLT CAP
 CACHE TROU
 STOPLOCK
 TAPA AGUJERO

Q.TY n.6

13



SCHIENALINO
 BÄCKREST
 DOSSERET
 BEIFAHRENRÜCKENLEHNE
 RESPALDO

Q.TY n.1

14



Z298
MOUSSE PROTETTIVA
 PROTECTIVE RUBBER PADS
 MOUSSE DE PROTECTION
 SCHUTZGUMMI
 ESPUMA ADHESIVA
 PROTECTORA

Q.TY n.2

15



VITE TCEI M6x25mm
 SCREW
 VIS
 SCHRAUBE
 TORNILLO

Q.TY n.2

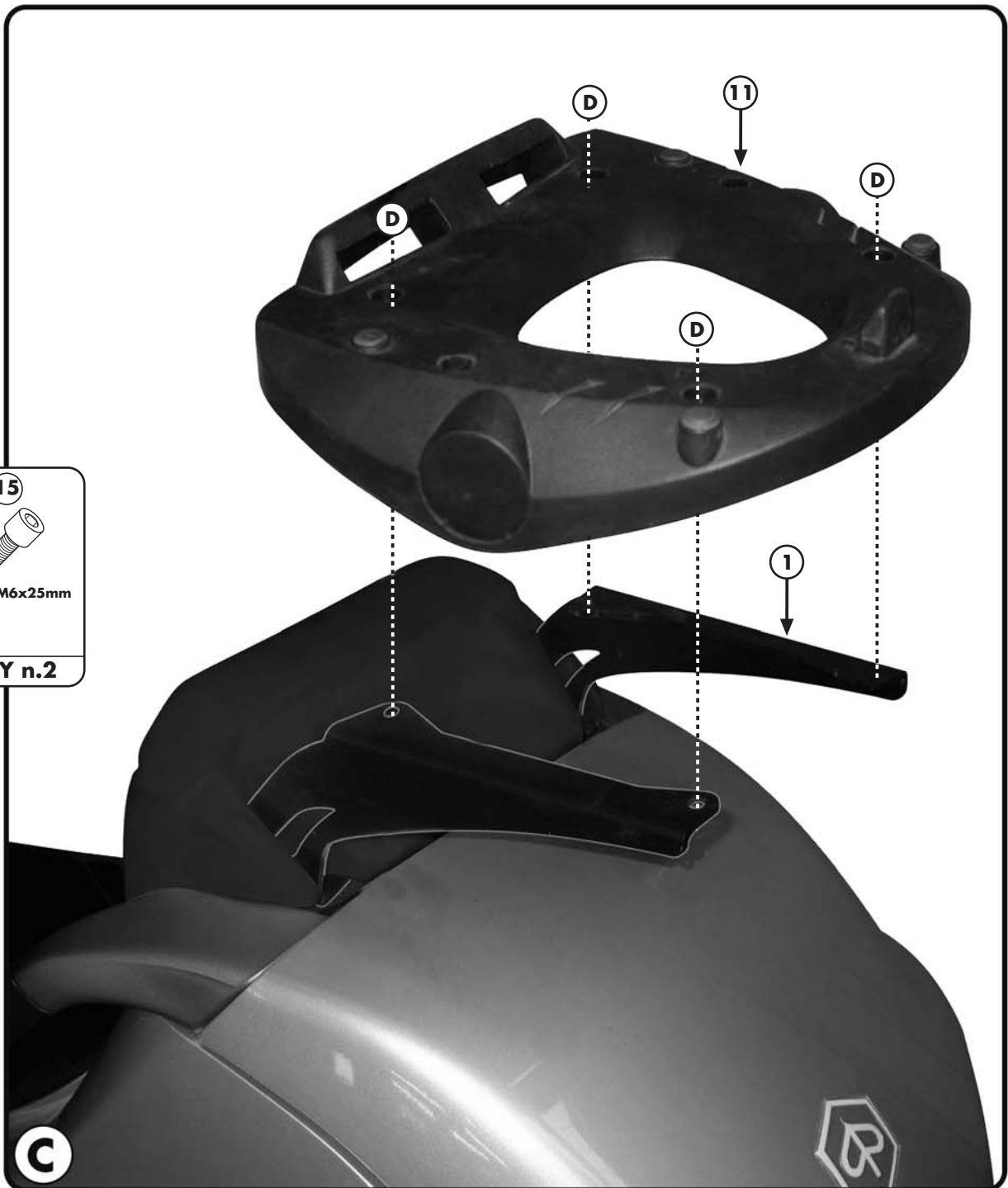
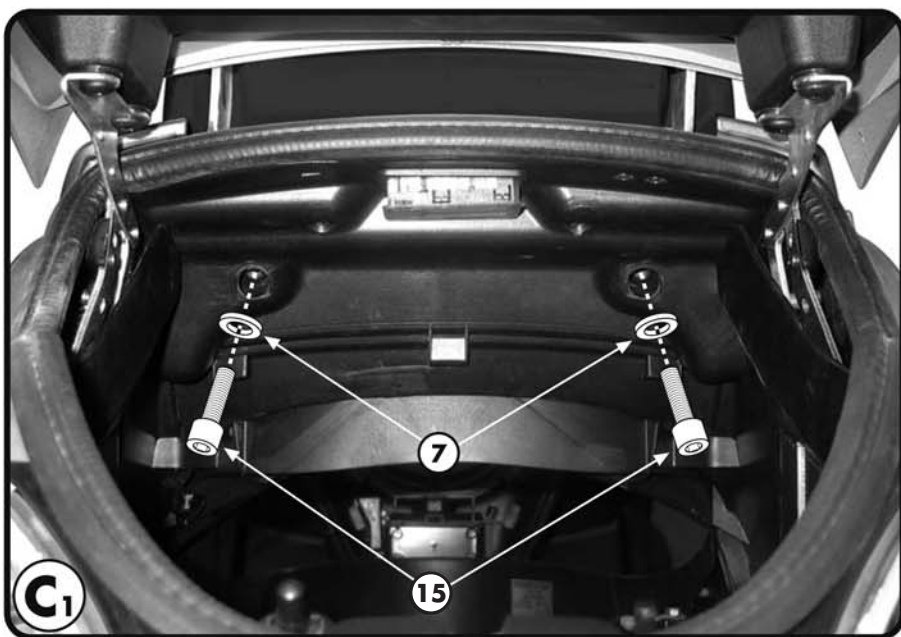

PORTAVALIGIA SPECIFICO - SPECIFIC CASE HOLDER
 PORTE-VALISE SPÉCIFIQUE - SPEZIFISCHER KOFFER-TRÄGER
 PORTA-EQUIPAJE ESPECÍFICO

PIAGGIO MP3 '06/'08
125 - 250cc

ISTRUZIONI DI MONTAGGIO - MOUNTING INSTRUCTIONS
 INSTRUCTIONS DE MONTAGE - BAUANLEITUNG - INSTRUCCIONES DE MONTAJE

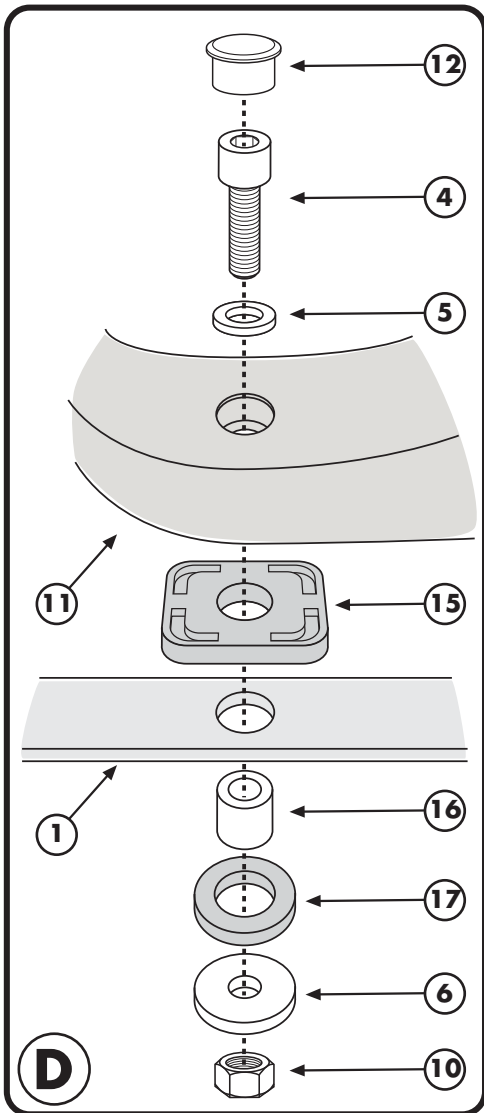

15

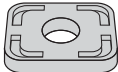

GOMMINO
 Z1822
 RUBBER
 CAOUTCHOUC
 GUMMI
 GOMA

Q.TY n.4

16



DISTANZIALE Ø11x11mm
 foro Ø6,5mm
 V687
 SPACER
 ENTRETOISE
 DISTANZSTÜCK
 DISTANCIADOR

Q.TY n. 4

17



RONDELLA IN GOMMA
 Z1823
 RUBBER WASHER
 RONDELLE EN GOMME
 GUMMISCHEIBE
 ARANDELA DE GOMA

Q.TY n.4

PORTAVALIGIA SPECIFICO - SPECIFIC CASE HOLDER
 PORTE-VALISE SPECIFIQUE - SPEZIFISCHER KOFFER-TRÄGER
 PORTA-EQUIPAJE ESPECIFICO

PIAGGIO MP3 '06/'08
125 - 250cc

ISTRUZIONI DI MONTAGGIO - MOUNTING INSTRUCTIONS
 INSTRUCTIONS DE MONTAGE - BAUANLEITUNG - INSTRUCCIONES DE MONTAJE

I ISTRUZIONI DI MONTAGGIO

1. SMONTARE LO SCHIENALINO ORIGINALE, FOTOGRAFIA A;
2. MONTARE IL SUPPORTO N°1 COME INDICATO IN FOTOGRAFIA B;
3. MONTARE LO SCHIENALINO, PARTICOLARE N°13, COME INDICATO IN FOTOGRAFIA C, FACENDO RIFERIMENTO PER IL FISSAGGIO ALLA FOTOGRAFIA C1;
4. MONTARE LA PIASTRA PORTAVALIGIA COME INDICATO IN FOTOGRAFIA C;
5. ULTIMARE IL MONTAGGIO CONTROLLANDO CHE TUTTE LE VITI SIANO SERRATE BENE.

ATTENZIONE: le protezioni adesive (particolare n°17) sono da utilizzare per proteggere lo sportello posteriore in fase di apertura

GB MOUNTING INSTRUCTIONS

1. REMOVE THE ORIGINAL BACKREST, PICTURE A;
2. MOUNT THE SUPPORT N° 1 AS SHOWN IN PICTURE B;
3. MOUNT THE BACKREST, PART N° 13, AS SHOWN IN PICTURE C, PAYING ATTENTION TO THE FIXINGS INDICATED IN PICTURE C1;
4. MOUNT THE PLATE AS SHOWN IN PICTURE C;
5. LASTLY CHECK THAT ALL SCREWS HAVE BEEN TIGHTENED.

ATTENTION: the protective rubber pads (part n° 17) should be used to protect the door of the rear boot when you open it.

F INSTRUCTIONS DE MONTAGE

1. DEMONTER LE DOSSERET D'ORIGINE, PHOTO A ;
2. MONTER LES SUPPORTS N°1 COMME INDIQUE EN PHOTO B ;
3. MONTER LE DOSSERET, PIECE N°13 COMME INDIQUE EN PHOTO C, POUR LA FIXATION, SE REFERER A LA PHOTO C1 ;
4. MONTER LA PLATINE COMME INDIQUE EN PHOTO C ;
5. TERMINER LE MONTAGE EN CONTROLANT LE BON SERRAGE DE TOUTES LES VIS.

ATTENTION: les protections adhesives (n°17) doivent etre utilise es pour proteger le capot arriere en position ouverte

D BAUANLEITUNG

1. MONTIEREN SIE DIE ORIGINAL RÜCKENLEHNE AB, BILD A;
2. MONTIEREN SIE DIE HALTERUNGEN NR. 1 WIE IM BILD B BESCHRIEBEN;
3. MONTIEREN SIE DIE RÜCKENLEHNE, TEIL NR. 13, WIE IM BILD C BESCHRIEBEN, NEHMEN SIE BEZUG AUF DIE HINWEISE VOM BILD C1;
4. MONTIEREN SIE DIE PLATTE WIE IM BILD C BESCHRIEBEN;
5. ZULETZT ÜBERPRÜFEN SIE, DASS ALLE SCHRAUBEN FESTGEZOGEN WURDEN.

ACHTUNG: verwenden Sie die Schutzgummis (Teil Nr. 17) um die Abdeckung des hinteren Staufachs beim Öffnen zu schützen.

ES

INSTRUCCIONES DE MONTAJE

1. DESMONTAR EL RESPALDO ORIGINAL, IMAGEN A;
2. MONTAR EL SOPORTE N°1 TAL Y COMO SE INDICA EN LA IMAGEN B.
3. MONTAR EL RESPALDO, ARTICULO N° 13, TAL Y COMO SE INDICA EN LA IMAGEN C, FIJANDOSE EN LA IMAGEN C1 PARA LA FIJACION.
4. MONTAR LA PARRILLA PORTAEQUIPAJES TAL Y COMO SE INDICA EN LA IMAGEN C;
5. FINALIZAR EL MONTAJE ASEGURANDOSE QUE TODOS LOS TORNILLOS HAN SIDO APRETADOS CORRECTAMENTE.

¡ATENCIÓN! las gomas protectoras adhesivas (detalle n° 17) se utilizan para proteger la ventanilla trasera durante la apertura